

**INSTRUCTION MANUAL**  
**ECO HEAD**  
 Ø 39.9 - 100.1 mm

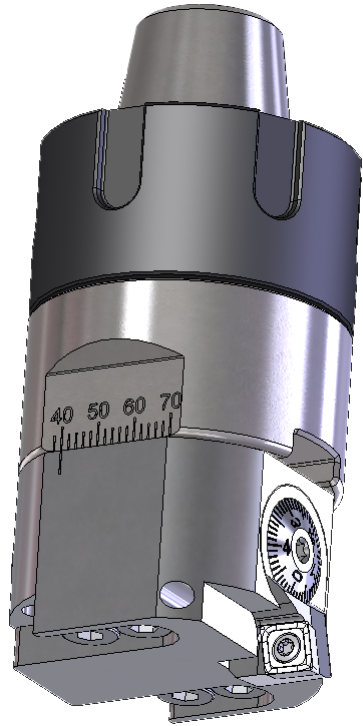

**assembling rough adjustment Ø 39.9 - 70.1mm**

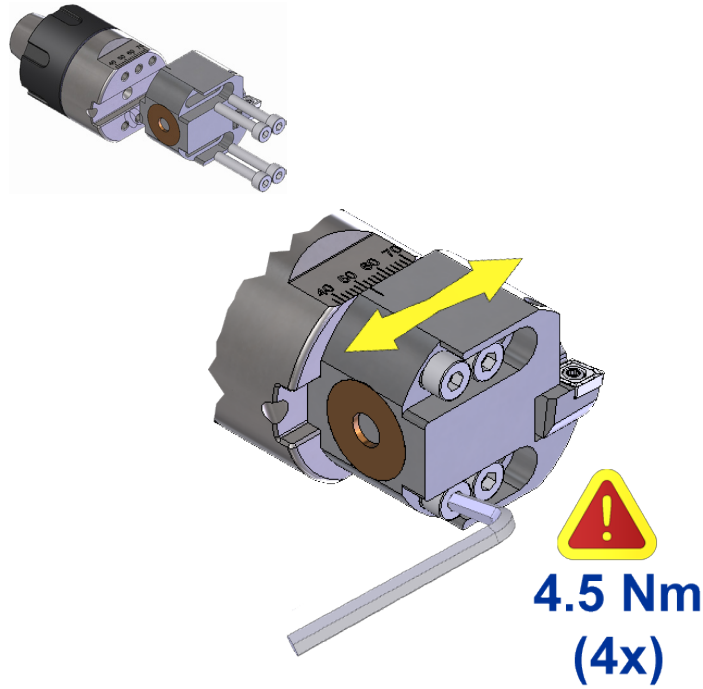

**assembling rough adjustment Ø 69.9 - 100.1mm**

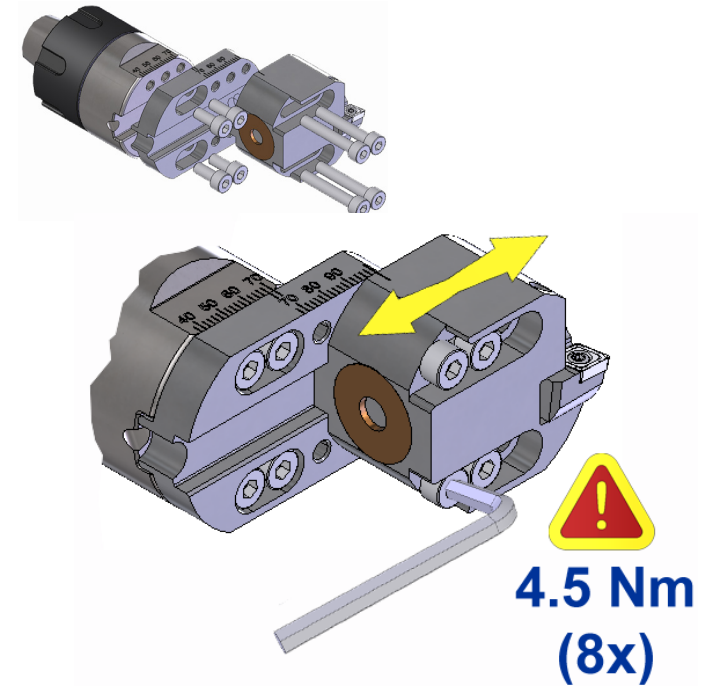

**diameter fine adjustment**

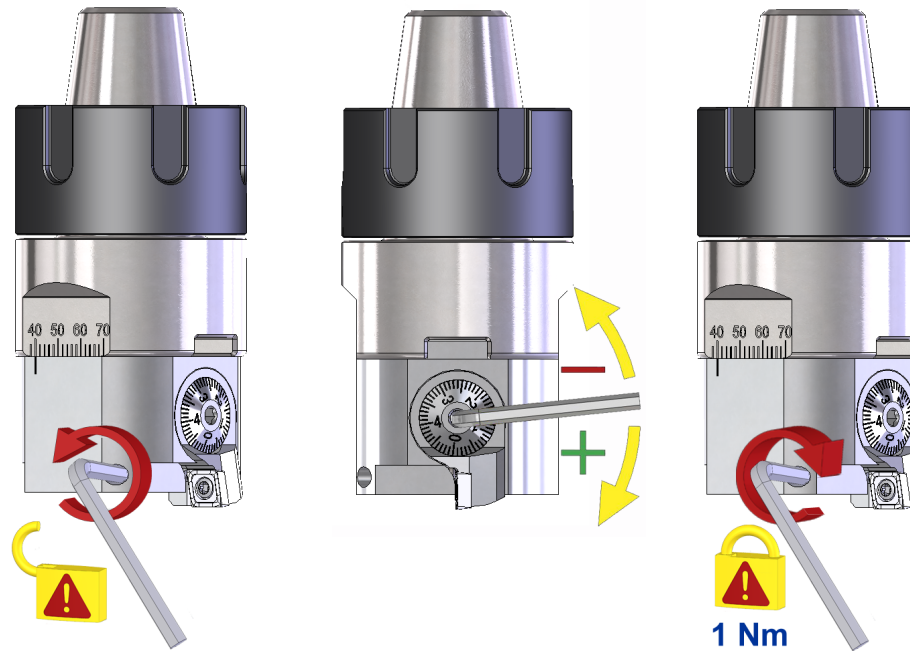

**scale / vernier**

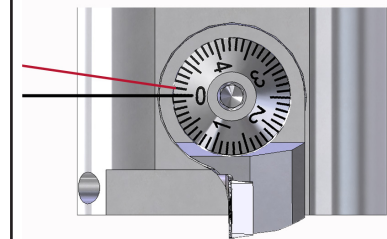

||| = 0,01 mm Ø

**maximum spindle speed**

V<sub>max</sub> = 450 m/min (Ø40-70)  
 V<sub>max</sub> = 250 m/min (Ø70-100)

**SWISS+TOOLS**

SWISS TOOL SYSTEMS AG  
 Wydenstrasse 28  
 CH-8575 Bürglen

Phone: +41 (0) 71 634 85 20  
 Fax: +41 (0) 71 634 85 29  
 www.swisstools.org

# Eco Head

from Ø39.9

- Flexible
- Universal
- Cost-efficient
- Scale for pre-adjustment
- 1 DIV = 0.01mm Ø



## ECO HEAD SET

Ø 39.9 - 100.1 mm



### Content

1 Case	
1 Base unit	ER 25
1 Fine boring head with insert holder	Ø 39.9 - 70.1
1 Extension bridge	Ø 69.9 - 100.1
4 Screws	M4 x 10
4 Screws	M4 x 25
1 Torx driver	T7
1 Allen wrench	SW1.5
1 Allen wrench	SW2.5
1 Allen wrench	SW3

**SWISS**  **TOOLS**

SWISS TOOL SYSTEMS AG  
Wydenstrasse 28  
CH-8575 Bürglen

Phone: +41 (0) 71 634 85 20  
Fax: +41 (0) 71 634 85 29  
[www.swisstools.org](http://www.swisstools.org)