

FINE BORING HEAD
Ø 24 - 171 mm

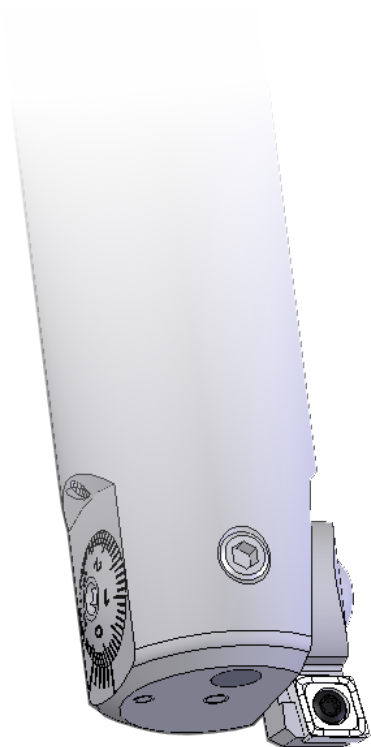

assembling boring head

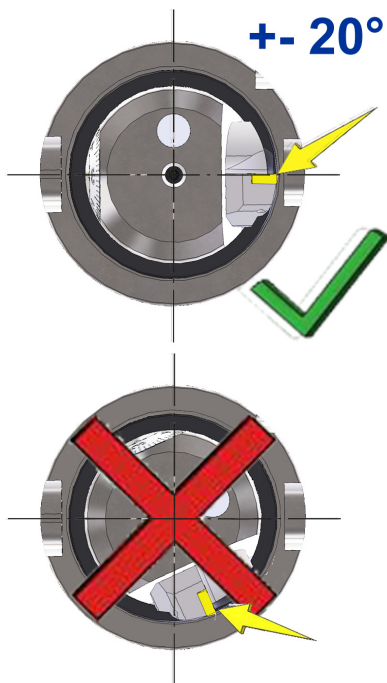

assembling insertholder

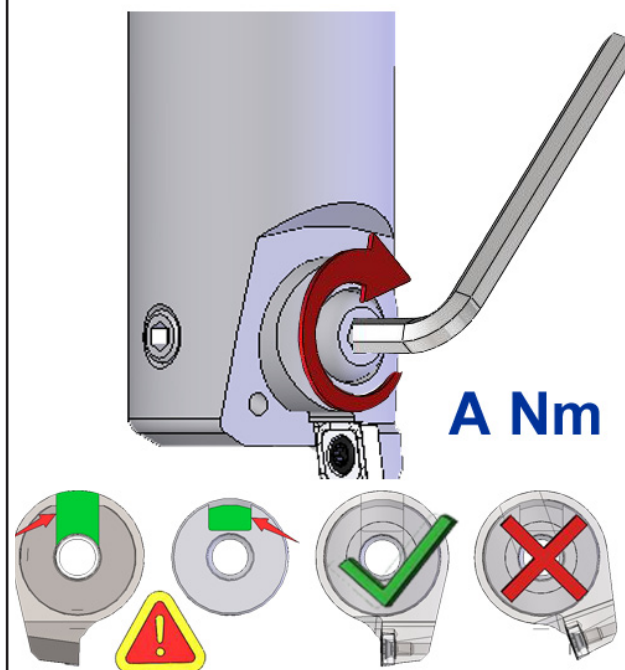

back boring (requires a reversal adapter)

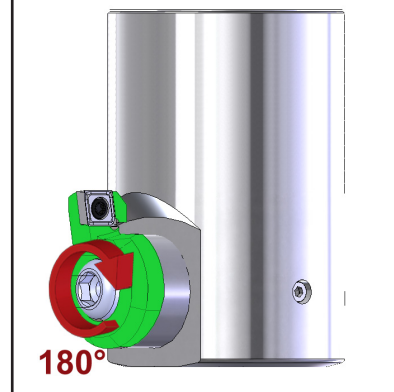

diameter adjustment

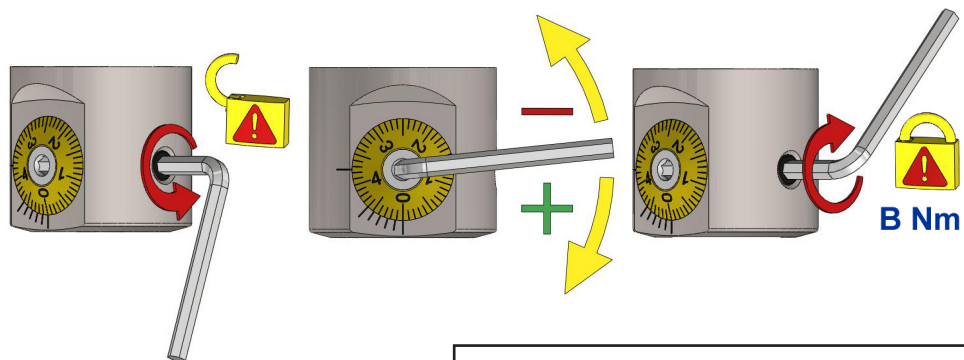

scale / vernier

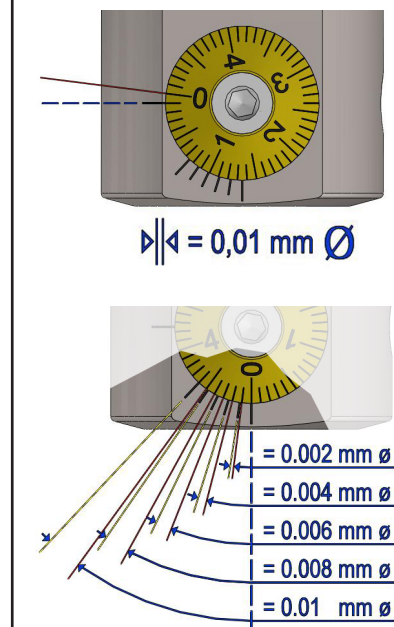

Fine boring head	Nm A	Nm B	max. rpm balanced	max. rpm unbalanced
D20 / Ø 24-31	2.4	1.4	12.000	9.000
D25 / Ø 31-40	5	2.4	10.000	7.500
D32 / Ø 40-51	9	3.4	8.000	5.250
D42 / Ø 51-67	20	5.2	6.500	4.000
D55 / Ø 67-87	35	8	5.000	3.000
D72 / Ø 87-116	35	8	4.000	2.500
D94 / Ø 116 - 171	35	8	3.000	1.750

SWISS+TOOLS

SWISS TOOL SYSTEMS AG
 Wydenstrasse 28
 CH-8575 Bürglen
 Phone: +41 (0) 71 634 85 20
 Fax: +41 (0) 71 634 85 29
 www.swisstools.org