

ROUGH BORING HEAD
Ø 23 - 153 mm

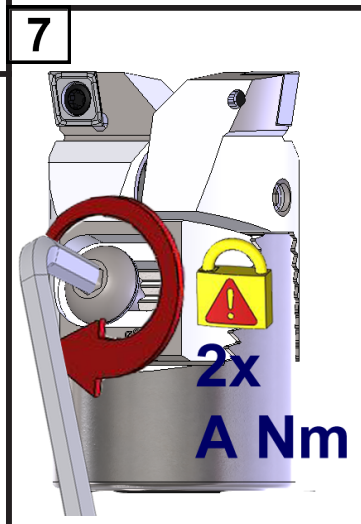

assembling insertholder

synchronous adjustment

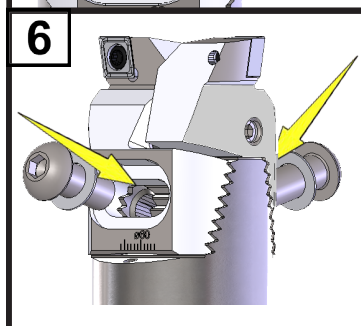
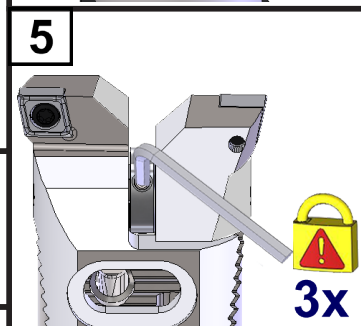
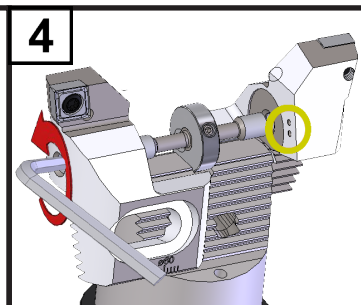
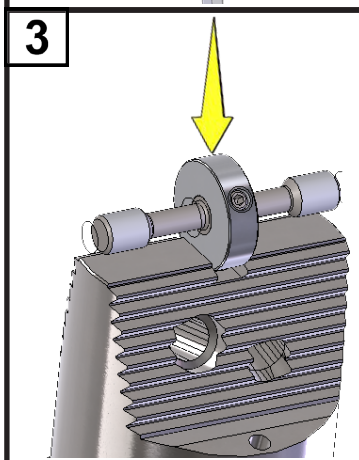
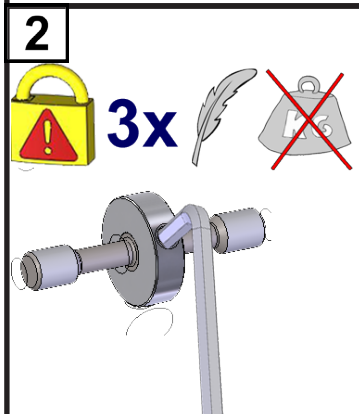
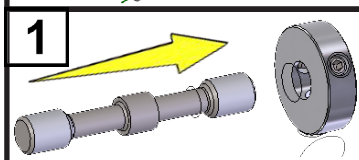
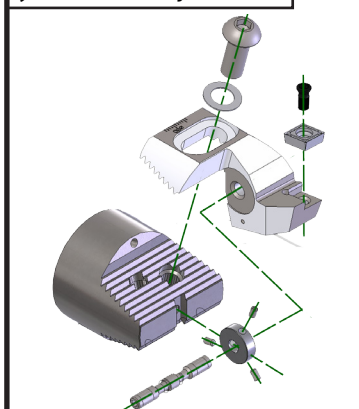

single adjustment

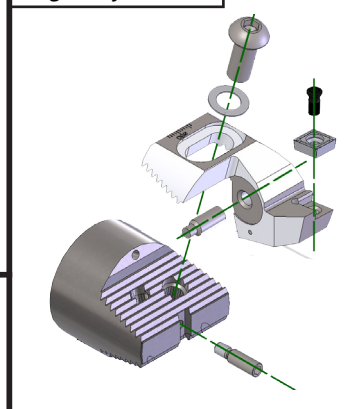

+ **6** + **7**

torque / revolution

Rough boring head	Nm A	max. rpm
D20 / Ø 23-31	2.4	12.000
D25 / Ø 31-40	5	10.000
D32 / Ø 40-51	9	8.000
D42 / Ø 51-67	20	6.500
D55 / Ø 67-87	35	5.000
D72 / Ø 87-116	35	4.000
D94 / Ø 116 - 153	35	3.000

diameter adjustment

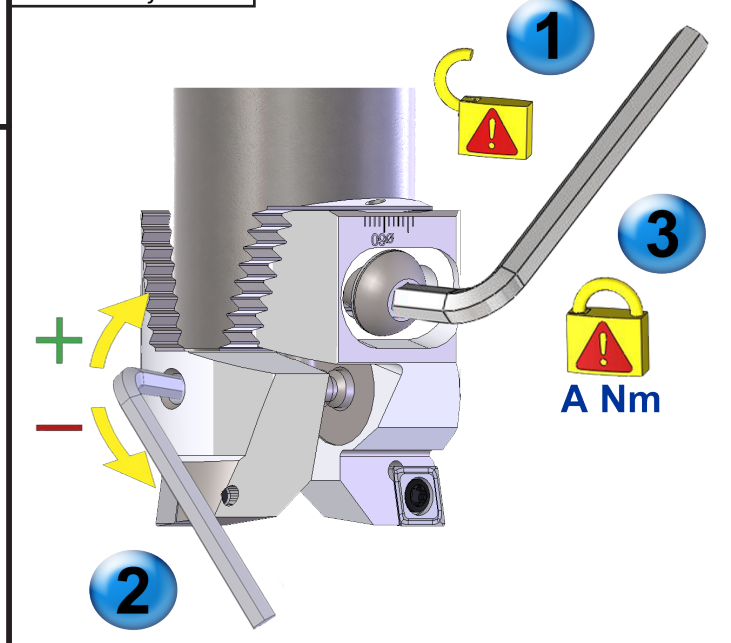

SWISS+TOOLS

SWISS TOOL SYSTEMS AG
 Wydenstrasse 28
 CH-8575 Bürglen

Phone: +41 (0) 71 634 85 20
 Fax: +41 (0) 71 634 85 29
 www.swisstools.org