

SCHNITT A-A (1 : 1)

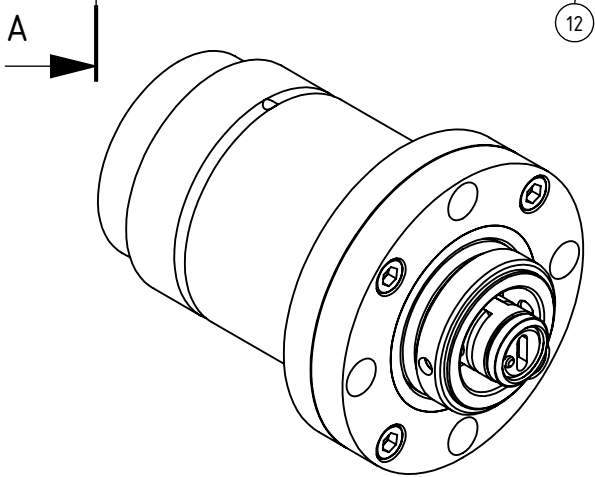
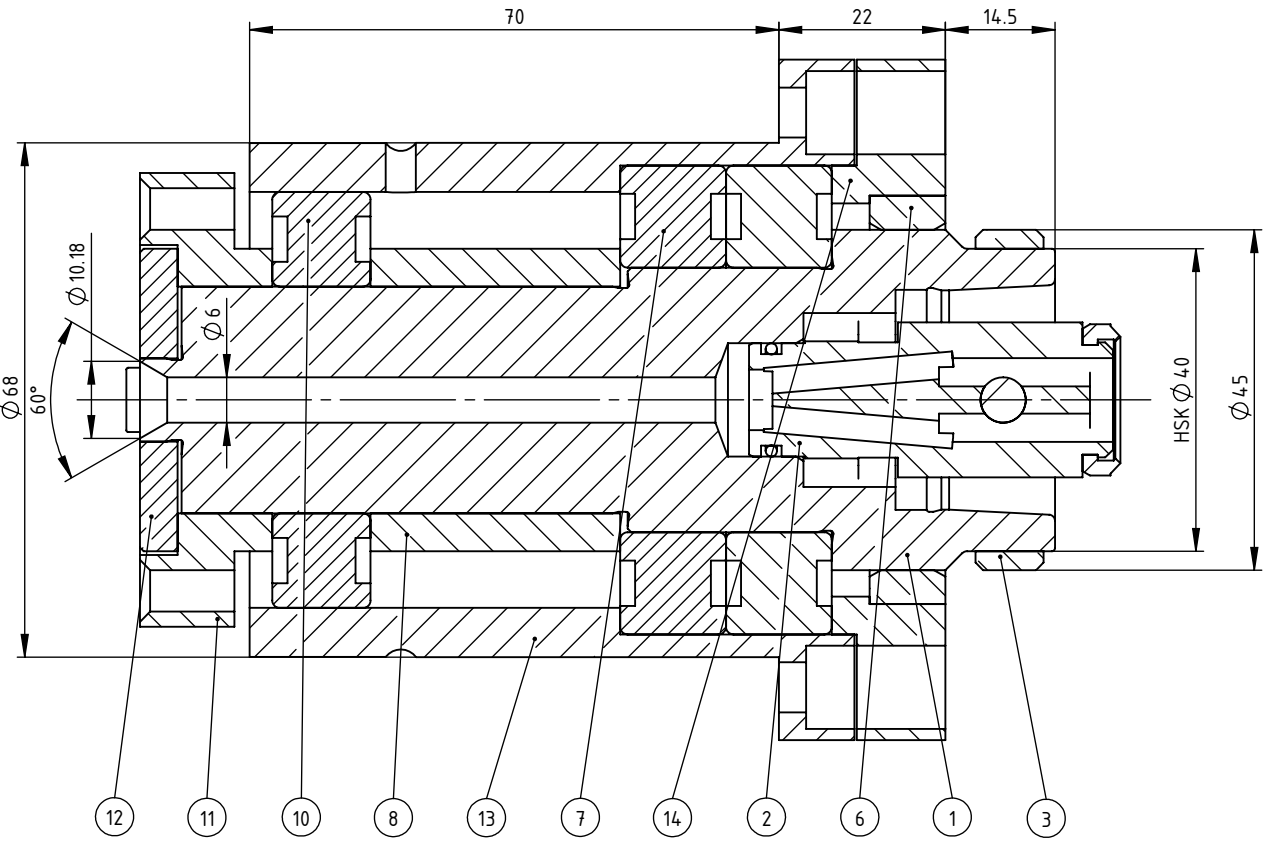

14	1	Deckel	641-01.08
13	1	Lagerbuchse	641-01.07
12	1	Deckel	640-02.04
11	1	Kupplung	640-02.03
10	1	Rillenkugellager 6006 2RS	Saurer 44.290
9	1	Fed-Keil	6h9 x 6 x 10
8	1	Distanzhülse	640-02.02
7	2	Spindellager 7007 A5 TYN VV SUL T4	Saurer 31219
6	1	Labyrinthring	GNM L 45 x 55 x 10
5	1	Schwerspannstift	ISO13337 Ø3x14
4	1	Halteschraube	HA6-ER2.002.010
3	1	Abdeckring	HA6-ER3.003.014
2	1	Spannpatrone	HA4-ER1.001.000
1	1	Spindel mit Spanneinheit	So1-HA4.K01.120
POS.	MENGE	Bezeichnung	Zeichnungsnummer

SWISSETOOLS

Werkzeugspindel
So1.HA4.K01.120

mit HSK 40
Gewicht: 1087g

Datum: 19.05.2015